

StarLink Series

Invisible Holographic Transparent LED Display

Applications



Shopping Malls



Showroom



Lobbies



Transportation



Fashion Stores



Car Dealers



Schools



Specification

Model	SL-TLED-2.5	SL-TLED-3.9	SL-TLED-6.25	SL-TLED10
Pixel Pitch (mm) (H/V)	P2.5 / P2.5	P3.91 / P3.91	P6.25 / P6.25	P6.25 / P6.25
Visual Transparency Rate	70%	80%	90%	90%
Physical Transparency Rate	35%	50%	65%	65%
Pixel Density (dot / m ²)	160,000	65,536	25,600	25,600
Module Size with pixels (mm) (W*H)	125x1000	250x1000 / 250x1175	250x1175 / 250x1475	250x1175 / 250x1475
Module Size with Edge (mm) (W*H)	/	250x1025 / 250x1200	250x1200 / 250x1500	250x1200 / 250x1500
Module Resolution (dot) (W*H)	50x400	64x256 / 64x300	40x188 / 40x236	40x188 / 40x236
Maximum Screen Height (m)	2	2.4	3	3
Brightness (cd / m ²)	1,200	3,000	4,000	4,000
Weight (kg / m ²)	6.5	6	5	6.5
Encapsulation Type	LED & IC packed in one			
Scanning Mode	Static Driving (Single Pixel Single Control)			
Lifespan	≥ 100,000.00 hours			
Gray Scale	65,536 (16bit)			
Maximum Power Consumption (w / m ²)	1000			
Average Power Consumption (w / m ²)	300			
Control System	Novastar			
Control Way	Synchronous / Asynchronous			
Input Voltage	AC100~240V 50/60 Hz			
Module Working Current	DC 4.2V ± 0.2V			
Operation Temperature	0~50 0C			
Operation Humidity	20%RH ~ 85%RH			
Storage Temperature	-20~60 0C			
Storage Humidity	10%RH ~ 85%RH			
Certificate	CE, EMC, LVD, CCC			

Note: Specifications are for reference only and are subjected to change without notice.

Project Case



Adhesive Transparent LED display is a cutting-edge technology that is designed to provide an efficient and flexible solution for visual communication. LED lamps and IC drivers are packed in one, as a result of extremely high transparency rate, thin display design, clear image and video output.

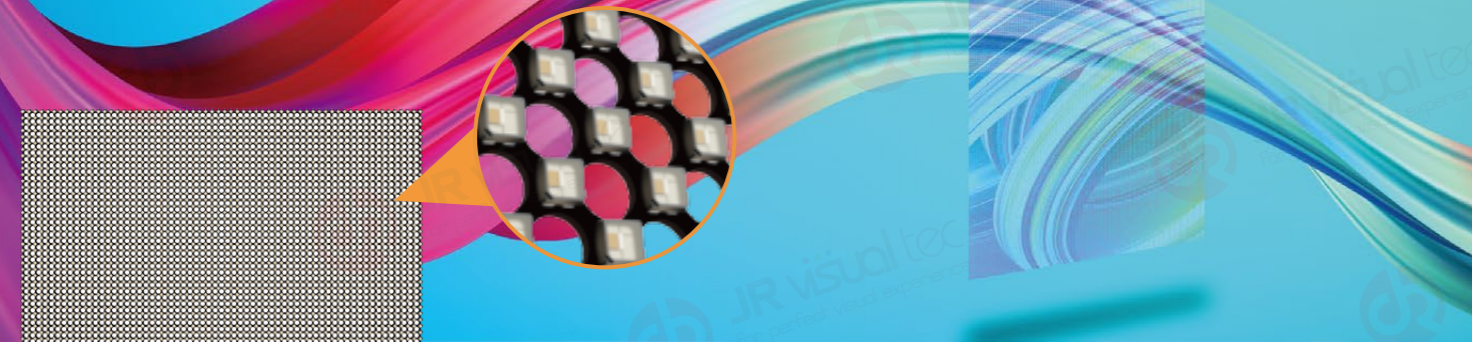

LED Module Dimension

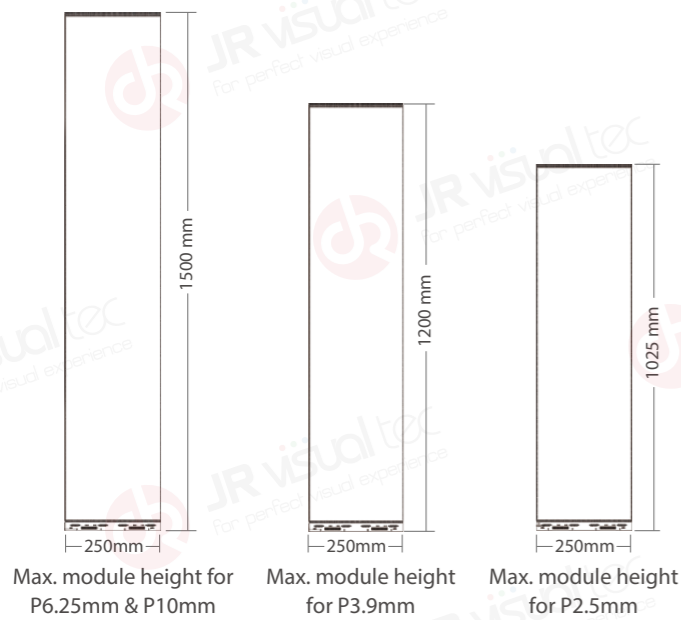

Control Box

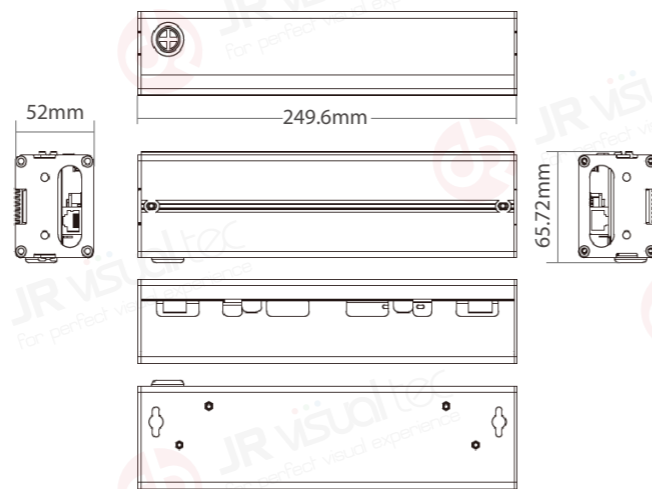

Flexible

Standard modules can be bent, cut, and used flexibly. The best partner for curved glass and special-shaped screen.

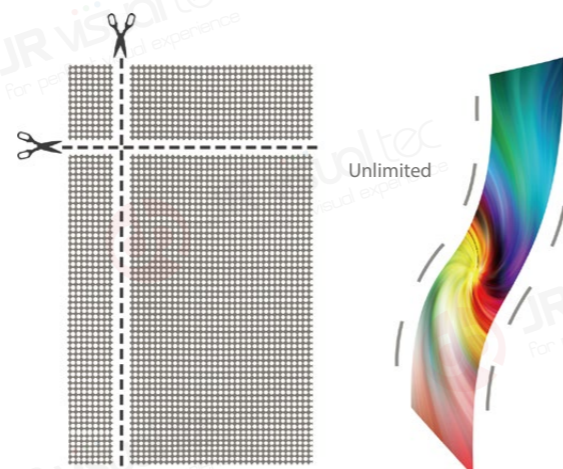

StarLink Transparent LED Poster



Free-standing

Which is movable and detachable. Display modules can be increased or decreased at any time according to the usage environment like exhibition booth, stage and other scenarios.



Hanging

The product is lightweight and easy to install for stage performance, door curtains show and other advertising scenes.

Thin - 2mm module thickness

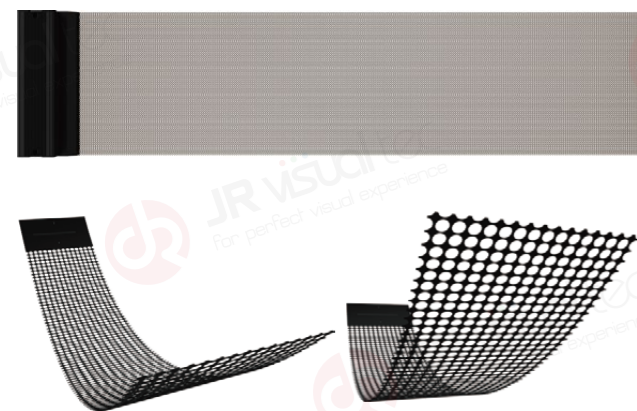

Transparent

It's a game-changer in the industry, without structural skeleton in the middle of the screen, which provides high visual transparency at 90% when glued onto a glass wall.



Light

Professional aesthetic design, thin and beautiful. Display body products. The weight is only 6KG/square meter.